



OWNER'S USE AND CARE GUIDE

AIR CONDITIONER

MODEL DAC080EB3GDB / DAC120EB3GDB



# Danby®

TO OBTAIN WARRANTY SERVICE YOU MUST PROVIDE A VALID PROOF OF PURCHASE. PLEASE STAPLE YOUR RECEIPT TO THIS PAGE FOR FUTURE REFERENCE.

---

## **IMPORTANT - GROUNDING METHOD**

This product is factory equipped with a power supply cord that has a three-pronged grounded plug. It must be plugged into a mating grounding type receptacle in accordance with the National Electrical Code and applicable local codes and ordinances. If the circuit does not have a grounding type receptacle, it is the responsibility and obligation of the customer to exchange the existing receptacle in accordance with the National Electrical Code and applicable local codes and ordinances. The third ground prong should not, under any circumstances, be cut or removed.

## CONTENTS

### AIR CONDITIONER

Owner's Use and Care Guide .....1-14

- Welcome
- Important Safety Information
- Features
- Installation Instructions
- Operation Instructions
- Care and Maintenance
- Troubleshooting
- Warranty

## **CAUTION:**

Read and follow all safety rules and operating instructions before first use of this product.

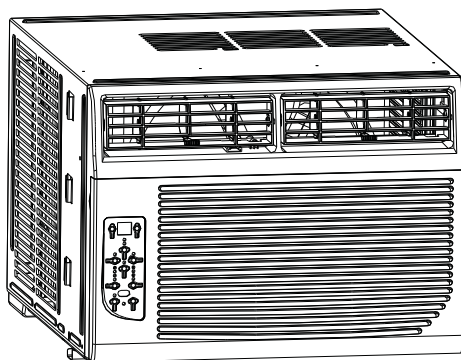

Model DAC080EB3GDB / DAC120EB3GDB

# WELCOME

Welcome to the Danby family. We are proud of our quality products, and we believe in dependable service, like you will find in this Owner's Use and Care Guide, and like you will receive from our friendly customer service department. Best of all, you will experience these values each and every time you use your Danby appliance. That is important, because your new appliance will be a part of your family for a long time.

For easy reference, we suggest you attach a copy of your sales slip/receipt to this page, along with the following information, located on the manufacturer's nameplate on the right side of the unit above the powercord.

**Note the information below; you will need this information to obtain service under warranty. To receive service, you must provide the original receipt.**

## NOTE: THIS UNIT IS NOT DESIGNED FOR "THROUGH-THE-WALL" INSTALLATION

Model No: \_\_\_\_\_

Serial No: \_\_\_\_\_

Date Purchased: \_\_\_\_\_

### NEED HELP?

Before you call for service, here are a few things you can do to help us serve you better:

**Read this Owner's Use and Care Guide:**

It contains instructions to help you use and maintain your appliance properly.

**If you received a damaged appliance:**

Immediately contact the retailer (or builder) that sold you the appliance.

**Save time and money:**

Check the Troubleshooting section at the end of the guide before calling. This section helps you solve common problems that may occur.

If you do need service, you can relax, knowing help is only a phone call away.



### WARNING

**Improper connection of the grounding plug can result in risk of fire, electric shock and/or injury to persons associated with the appliance. Check with a qualified service representative if in doubt that the appliance is properly grounded.**



# Important Safety Information

## READ AND FOLLOW ALL SAFETY INSTRUCTIONS

**FOR YOUR SAFETY:** Read these instructions carefully before operating the unit.

### ELECTRICAL SPECIFICATIONS

- 1) All wiring must comply with local and national electrical codes and must be installed by a qualified electrician. If you have any questions regarding the following instructions, contact a qualified electrician.
- 2) Check available power supply and resolve any wiring problems BEFORE installing and operating this unit.
- 3) This 115V air conditioner uses 9.5 or less nameplate amps and may be used in any properly wired, general purpose household receptacle. See **Table 1** for the specifications for the individual branch circuit.
- 4) For your safety and protection, this unit is grounded through the power cord plug when plugged into a matching wall outlet. If you are not sure whether your wall outlet is properly grounded, please consult a qualified electrician.
- 5) The wall outlet must match the 3-prong plug on the service cord supplied with the unit. **DO NOT** use plug adapters. See **Table 2** for receptacle and fuse information. If it is necessary to use an extension cord to connect your air conditioner, **use an approved “air conditioner” extension cord only** (available at most local hardware stores).
- 6) The rating plate on the unit contains electrical and other technical data. The rating plate is located on the right side of the unit, above the power cord.

TABLE 1 DAC080EB3GDB	
Suggested Individual Branch Circuit	
Nameplate Amps 6.2	*AWG Wire Size 16
AWG- American Wire Gauge *Based on copper wire at 60°C temperature rating.	

TABLE 1 DAC120EB3GDB	
Suggested Individual Branch Circuit	
Nameplate Amps 9.5	*AWG Wire Size 14
AWG- American Wire Gauge *Based on copper wire at 60°C temperature rating.	

TABLE 2	
Receptacle and Fuse Types	
Rated Volts	125
Amps	15
Wall Outlet	
Fuse Size	15
Time Delay Fuse (or Circuit Breaker)	Plug Type



# Important Safety Information

**READ AND FOLLOW ALL SAFETY INSTRUCTIONS**

**FOR YOUR SAFETY:** Read these instructions carefully before operating the unit.

## ENERGY SAVING TIPS

Your Danby appliance is designed to be highly efficient in energy savings. Follow these recommendations for greater efficiency.

- 1) Select a thermostat setting that suits your comfort needs and leave at that chosen setting.
- 2) The air filter is very efficient in removing airborne particles. Keep the air filter clean at all times. (usually cleaned every 2 weeks depending on indoor air quality).
- 3) Use drapes, curtains or shades to keep direct sunlight from penetrating and heating the room, but do not allow drapes or curtains to obstruct the air flow around the unit.
- 4) Start your air conditioner before the outdoor air becomes hot and uncomfortable, to avoid an initial period of discomfort while the unit is cooling off the room.
- 5) When outdoor temperatures are cool enough, use the Fan Mode only, on High, Med., or Low setting. This circulates indoor air, providing some cooling comfort, and utilizes less electricity than when operating on a cooling setting.



## Features

**Fresh Air Ventilation Switch**  
(open for Fan only operation, only available on DAC120EB3GDB)

Exterior Air Inlet

Control Panel

Interior Air Inlet

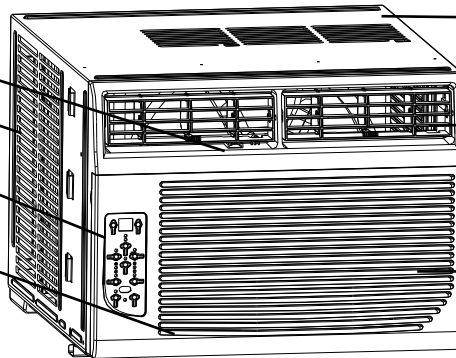

Cabinet

Interior Air Outlet

Air Filter



## Installation Instructions



### ELECTRIC SHOCK HAZARD

To avoid the possibility of personal injury, disconnect power to the unit before installing or servicing.

**NOTE:** Your Room Air Conditioner is designed for easy installation in a single or double-hung window. This unit is NOT designed for vertical (slider type) windows and/or through-the-wall applications.

### TOOLS NEEDED FOR INSTALLATION:

- **Screwdrivers:** Phillips and flat head.
- **Power Drill:** 1/8" (3.2mm) diameter drill bit.
- **Pencil**
- **Measuring Tape**
- **Scissors**
- **Carpenter's Level**

**NOTE:** Save the shipping carton and packing materials for future storage or transportation. From carton, remove the plastic bag containing the installation hardware kit necessary for the installation of your air conditioner. Please check the contents of hardware kit against the corresponding model check list, prior to installation of the unit. See Fig. 1.



## CAUTION

Because the compressor is located on the controls side of the unit (left side), this side will be heavier and more awkward to manipulate. Inadequate support on control side of the unit can result in personal injury and damage to your unit and property. Therefore, it is recommended that you have someone assist you during the installation of this unit.



# Installation Instructions

## INSTALLATION HARDWARE

Fig. 1

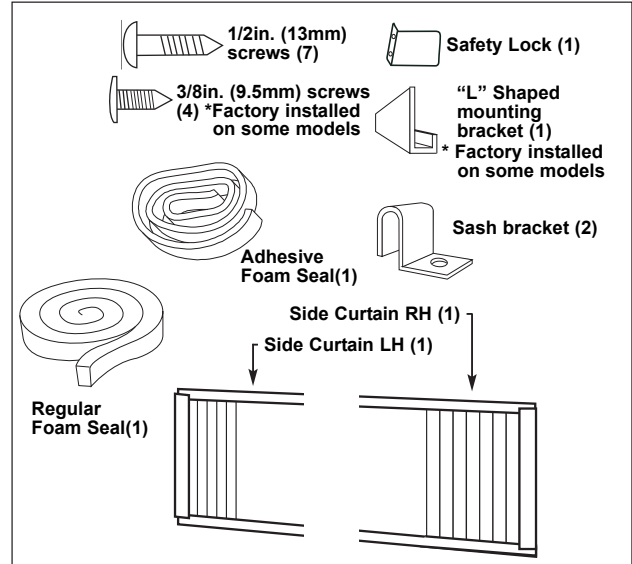

## LOCATION

- A) This room air conditioner is designed to fit easily into a single or double hung window. However, since window designs vary, it may be necessary to make some modifications for safe, proper installation.
- B) Make sure window and frame are structurally sound and free from dry and rotted wood.
- C) For maximum efficiency, install the air conditioner on a side of the house or building which favours more shade than sunlight. If the unit is in direct sunlight, it is advisable to provide an awning over the unit.
- D) Provide sufficient clearance around the cabinet to allow for ample air circulation through the unit (**See Fig. 2**). The rear of the unit should be outdoors and not in a garage nor inside a building. Keep unit as far away as possible from obstacles/obstructions and at least 30" above the floor or ground. Curtains and other objects within a room should be prevented from blocking the air flow.
- E) Be certain the proper electrical outlet is within reach of the installation. Use only a single outlet circuit rated at 15 amps. All wiring should be in accordance with local and national electrical codes.
- F) DO NOT install unit where leakage of combustible gas is suspected. Your air conditioner may fail to operate in air containing oils (including machine oils), sulfide gas, near hot springs, etc.

**NOTE:** Your unit is designed to evaporate condensation under normal conditions. However, under extreme humidity conditions, excess condensation may cause the basepan to overflow to the outside. The unit should be installed where condensation run-off cannot drip on pedestrians or neighboring properties.



# Installation Instructions

## LOCATION

Fig. 2

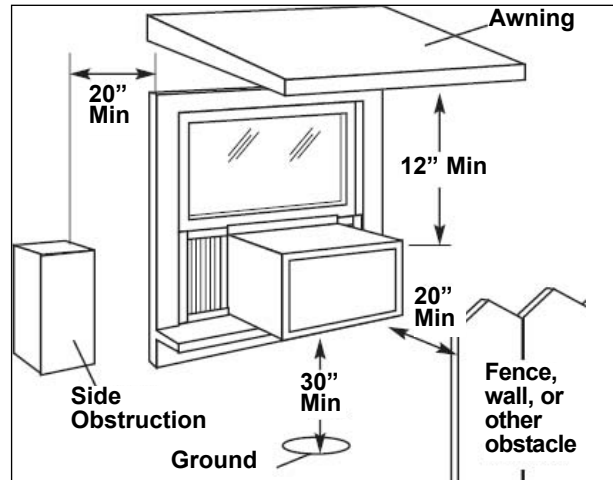

### 1) Assembly of the Upper Channel to Cabinet. (Factory installed on some units)

- “L” Shaped Top Channel: Install the “L” shaped channel to the top of the cabinet as shown in Fig. 3, using four (4) 3/8” screws.

### 2) Assembly of the Side Curtains to Cabinet.

- Extend the shutter from the shutter frame and slide it into the shutter tabs on the side channel of the air conditioner, as shown in Fig. 4.
- Slide the shutters into the top (“L” Shaped) and bottom (“U” Shaped) channels. The shutters are identified (on frame) as left and right.

### 3) Completing the Installation

- Cut the foam (non adhesive) sealing strip to fit the area of the window sill that the air conditioner will rest on.

Fig. 3

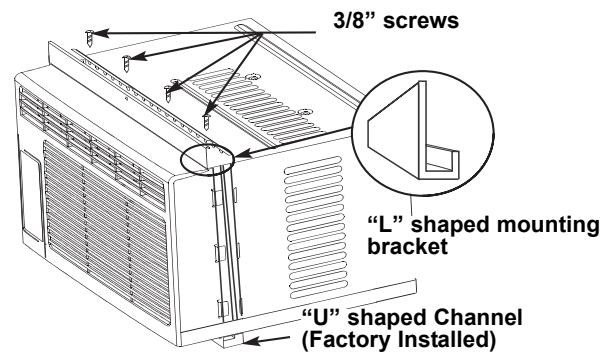
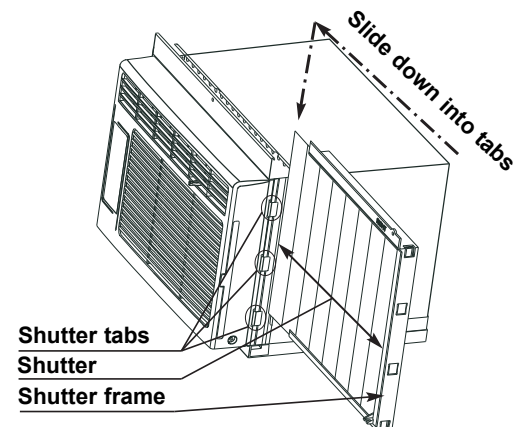

Fig. 4





# Installation Instructions

## 3) Completing the Installation (cont)

- Carefully place the air conditioner into the window with the “L” shaped mounting bracket (on top) positioned in front of the upper window sash. The bottom of the cabinet should be positioned on the “recessed” portion of the window frame. Pull the window down until it rests just behind the front flange of the (top) “L” shaped mounting bracket (**See Fig. 5**).
- Expand the shutter frames (fully) on each side and secure the top of the frames to the window sash using one 1/2” screw on each side and one in the “L” shaped mounting bracket (**Fig. 5**).
- Secure the shutter clamp on each side of the lower part of the shutter and secure to the window sill using one 1/2” screw on each side (**Fig. 5**).
- Place the second foam sealing strip to fit the opening between the inside and outside windows, then attach the safety lock to the outside window frame using one 1/2” screw (**See Fig. 6**).

**PLEASE NOTE:** Window applications come in a variety of different styles. Therefore, it may be necessary to modify or improvise your particular installation. Check that the air conditioner is tilted downwards to the outside, about 3° to 4°, as shown in **Fig. 7**. After proper installation, condensed water should not drain from the overflow drain hole during normal use. If you notice water leaking out, check the angle of tilt, and make any necessary adjustments. However, on a very humid day, water leakage can occur – this is normal.

Measure the tilt angle from the cabinet’s edge. The distance H should be approximately 3/4” to 1” for DAC080EB3GDB. The distance H should be approximately 1” to 1 3/8” for DAC120EB3GDB.

**Fig. 5**

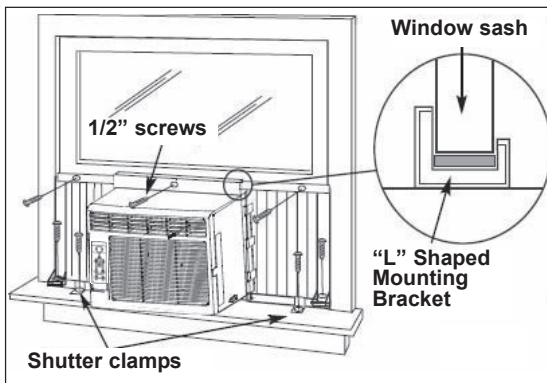

**Fig. 6**

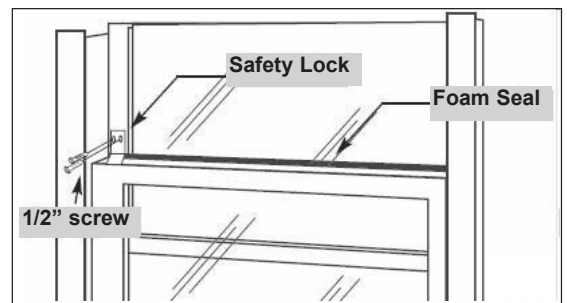

**Fig. 7**

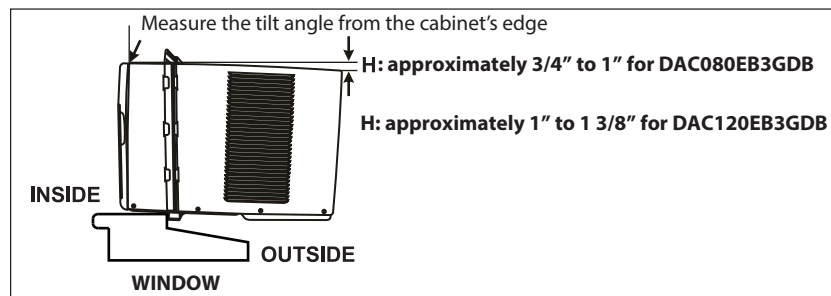







# Operating Instructions

## KEY PAD FEATURES

**LED DISPLAY:** Displays the following information independently - Set Temperature, Ambient Room Temperature and Auto Timer On/Off settings.

 **POWER:** Turns unit On/Off.

NOTE: The unit will automatically launch the Energy Saver function when it is in Cool, Dry, and Auto modes.

 **MODE:** Allows you to scroll through and select the desired operating mode: Cool, \*Dry, Fan Only and \*\*Auto. The selected mode will be denoted by the adjacent indicator light.

### Note on \*\*Auto operation:

Auto is a pre-set factory program that automatically defines the mode and the fan speed, based on the set temperature you have chosen. An example of Auto operation is as follows.

If you would like to cool down your room, your desired/ set temperature will be below the room temperature, and your air conditioner will go into cooling mode. Once the room has reached your desired temperature, the air conditioner will switch to Fan mode, and circulate the cooled air around the room. When the temperature in the room goes up, the unit will switch back to cooling mode, and the Auto cycle will start again.

### Note on \*Dry operation:

Please note that in this mode you cannot set the desired humidity level, it is automatically pre-set. The fan speed in this setting is defaulted to "low", but since the compressor is operating in order to remove moisture from the air, you will experience a degree of cooling as a by-product.

 **FAN SPEED:** Select from four different fan settings: Low, Medium, High and Auto during Cool and Fan Only mode. Please note, during 'Dry' mode the fan speed is automatically defined.

 **ENERGY SAVER:** This is the default setting on this model. The unit will automatically cycle the fan on and off while the compressor is not in use. The fan will continue to run for 3 minutes after the compressor shuts off. The fan then cycles on for 2 minutes at 10 minute intervals, until the room temperature is above the set temperature. At this point, the compressor turns back on and cooling re-starts. When the unit is in Energy Saver mode, the indicator light above the Energy Saver button will be illuminated. You can take the unit out of Energy Saver mode by pressing the Energy Saver button – the indicator light above the button will turn off. If you choose the non-Energy Saver option, the fan will run continuously when the compressor is not in use.

 **TEMP / TIMER CONTROL:** Used to increase or decrease the Temperature setting in 1°C / °F increments, and Auto-Timer On/Off settings in 30min./1hr. increments. **Note:** This appliance allows you select the temperature scale to be displayed in either "Celsius" or "Fahrenheit" according to your preference. To change the temperature scale displayed on the electronic display, press both the "Temp/Timer" adjust arrows simultaneously to alternate between "Celsius" & "Fahrenheit".

 **CHECK FILTER:** The adjacent indicator light will illuminate as a reminder to clean the air conditioner filter (see page 11). Once the filter has been cleaned and replaced, depress the Check Filter button in order to resume operation.

 **SLEEP MODE:** In this mode, the selected temperature will increase (when in cooling mode) by 2 °F one half-hour after Sleep mode has been selected. The temperature will then increase by another 2 °F after an additional half hour. This new temperature will be maintained for 6 hours before returning to the originally selected temperature. This ends the Sleep mode and the unit will continue to operate as originally programmed. The Sleep mode program can be cancelled at any time during operation by pressing the Sleep button again.

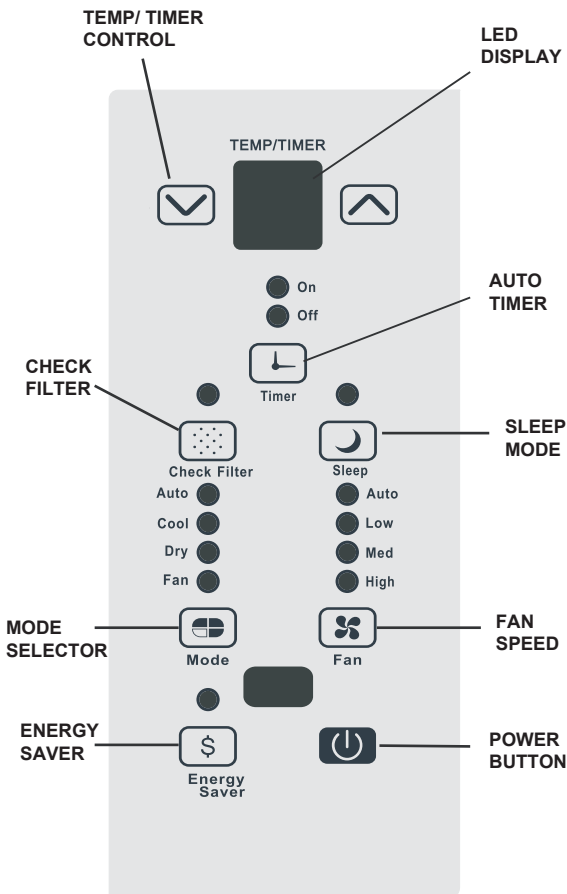



# Operating Instructions

 **AUTO-TIMER:** Used to initiate the Auto On/ Auto Off timer.

**While the Air Conditioner is off (Auto-On):**

- 1) Press the Auto-Timer button once and the adjacent Auto-On indicator light will illuminate.
- 2) Use the Temp/Timer control cursors to select a delayed On time of up to 24 hours.
- 3) Select the appropriate mode under which you want the unit to operate (Auto-Cool-Dry-Fan Only)
- 4) Select the fan speed setting.
- 5) The time you selected will appear in the LED display.

**While the Air Conditioner is on (Auto-Off):**

- 1) Press the Auto-Timer button twice and the adjacent Auto-Off indicator light will illuminate.
- 2) Use the Temp/Timer control cursors to select a delayed Off time of up to 24 hours.
- 3) The time you selected will appear in the LED display. The Auto On and Auto Off timer can operate during the same program by defining the Auto-Off parameters immediately after the Auto On parameters. The Auto-Timer may be cancelled at any time by turning the unit On/Off. For example, if you want to let the machine on one hour later and last for one hour and then stop, set auto on "1" and auto off "2".

**This is a "one-shot" timer.** It does not continue to cycle on and off. It will turn the unit on (IF set by the user) ONE time. It will turn the unit off (IF set by the user) ONE time. If you require the unit to turn on/off again automatically, then you must set the timer again.

## USING THE REMOTE CONTROL

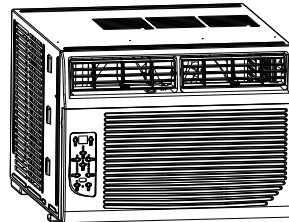

Location of the remote controller.

- Use the remote controller within a distance of 8 meters from the appliance, pointing it towards the receiver. Reception is confirmed by a beep.

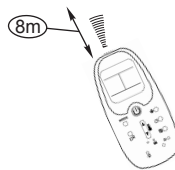

	<b>CAUTION</b>
<ul style="list-style-type: none"> <li>• The air conditioner will not operate if curtains, doors or other materials block the signals from the remote controller to the indoor unit.</li> <li>• Prevent any liquid from falling into the remote controller. Do not expose the remote controller to direct sunlight or heat.</li> <li>• If the infrared signal receiver on the indoor unit is exposed to direct sunlight, the air conditioner may not function properly. Use curtains to prevent the sunlight from falling on the receiver.</li> <li>• If other electrical appliances react to the remote controller, either move these appliances or call the service depot.</li> </ul>	



# Operating Instructions

## REMOTE CONTROLLER BUTTONS

Electronic  
Display

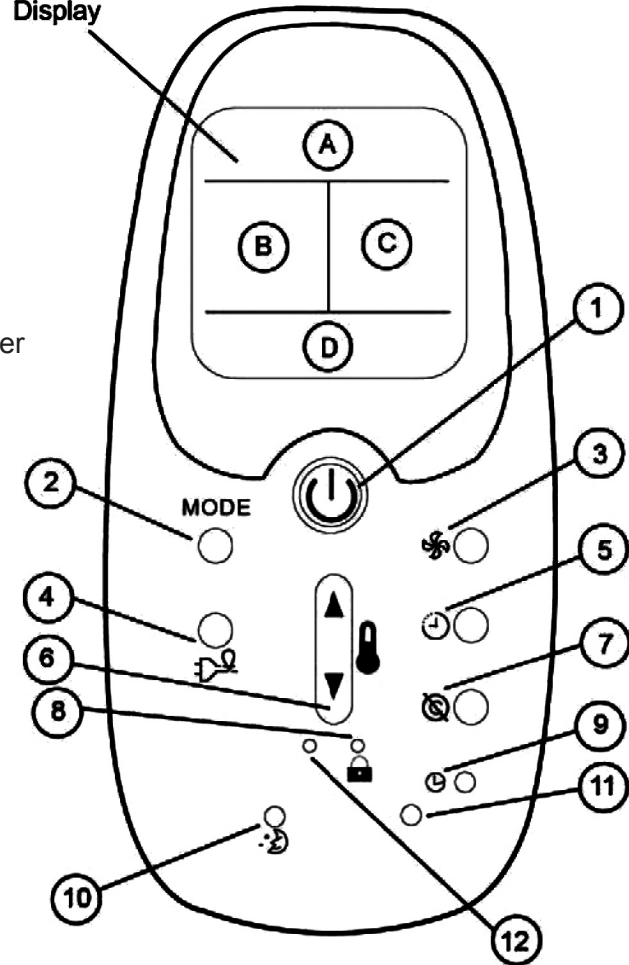

### Electronic Display

Displays the following information:

**A:** Remote Control power On/Off and Mode Icons

**B:** Clock and Auto-Timer settings

**C:** Current set temperature

**D:** Fan speed setting control buttons

1) Power switch.

NOTE: The unit will automatically launch the Energy Saver function when it is in Cool, Dry, and Auto modes.

2) Mode

3) Fan Speed

4) Energy Saver - Default setting which allows the fan to cycle on and off (instead of running continuously) when the compressor is not in use.

5) Auto-Timer

6) Used to increase or decrease temperature settings in 1° increments on the Celsius or Fahrenheit scale.

7) Cancels current Timer ON/OFF settings.

8) Lock prevents the remote control settings from inadvertently being changed.

9) Clock: Depress the button for 3 seconds in order to set the clock. Press the increase or decrease arrow to adjust the clock in 1 minute intervals. Holding down the increase or decrease arrow will adjust the time in 10 minute intervals.

10) Used to activate the SLEEP program.

11) Toggle the LED backlight on/off.

12) Restore remote control default settings.



# Operating Instructions

## CHANGING THE BATTERIES ON THE REMOTE

To operate the hand held remote control will require two “AAA” Alkaline batteries (included).

**Batteries should be replaced when:**

- a) No signal (beep) is heard when attempting to program the main unit.
- b) The main unit does not respond to a command issued by the remote control.

**Battery replacement:**

- 1) Slide the rear cover on the remote in the direction of the arrow. Continue pulling (gently) until the cover separates completely from the unit.
- 2) Insert (2) batteries (AAA) following the same orientation (polarity) depicted inside the battery chamber (+/-).
- 3) Re-install rear cover.
- 4) If the remote control will not be used for extended periods of time (vacations etc.), batteries should be removed.

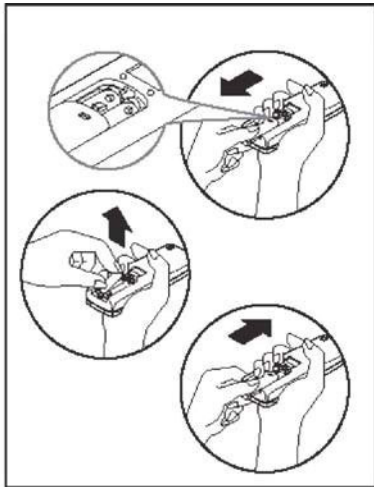

Protect the remote control from high temperatures, and keep it away from radiation exposure.

Keep the control panel receiver out of direct sunlight.

If the remote control will not be used for extended periods of time (vacations, etc.) batteries should be removed.

Do not mix old and new batteries.

Do not mix alkaline, standard (carbon-zinc), or rechargeable (ni-cad, ni-mh, etc) batteries.

This Class B digital apparatus complies with the Canadian ICES-003 standard. CAN ICES-3(B)

The remote operates within a range of 8 meters (26 ft.) from the receiver located inside the main unit. Any obstruction between the receiver and remote may cause signal interference, limiting the ability to program the main unit.

NOTE: This equipment has been tested and found to comply with the limits for a Class B digital device, pursuant to Part 15 of the FCC Rules. These limits are designed to provide reasonable protection against harmful interference in a residential installation. This equipment generates, uses and can radiate radio frequency energy and, if not installed and used in accordance with the instructions, may cause harmful interference to radio communications. However, there is no guarantee that interference will not occur in a particular installation. If this equipment does cause harmful interference to radio or television reception, which can be determined by turning the equipment off and on, the user is encouraged to try to correct the interference by one or more of the following measures:

- 1) Reorient or relocate the receiving antenna
- 2) Increase the separation between the equipment and receiver
- 3) Connect the equipment into an outlet on a circuit different from that to which the receiver is connected
- 4) Consult the dealer or an experienced radio/TV technician for help

Changes or modifications not approved by the party responsible for FCC compliance could void the user’s authority to operate the equipment.

This appliance complies with Part 15 of the FCC Rules. Operation is subject to the following two conditions:

- 1) This device may not cause harmful interference.
- 2) This device must accept any interference received, including interference that may cause undesired operation.



# Care and Maintenance



**NOTE:** In order to avoid electric shock, please turn off the A/C and unplug the plug before maintenance or repair.

## CLEANING

When cleaning the air conditioner be sure to **disconnect the power cord from the electrical outlet.**

1. **DO NOT** use gasoline, benzene, thinner, or any other chemicals to clean this unit, as these substances may cause damage to the finish and deformation of plastic parts.
2. Never attempt to clean the unit by pouring water directly over any of the surface areas, as this will cause deterioration of electrical components and wiring insulation.

## AIR FILTER

If the air filter becomes clogged with dust, air flow is obstructed and reduces efficiency. The air filter should be cleaned every 2 weeks.

### AIR FILTER REMOVAL:

The air filter is located behind the air intake front grill. To remove the air filter, grasp the filter handle on the front of the grill and slide it out to the right.

To reinstall the air filter, reverse the above procedures. The air filter must be vacuumed or washed by hand in warm water. Dry thoroughly before re-installing.

### CLEANING AIR FILTER:

1. Use a vacuum cleaner with soft brush attachment.
2. Wash the filter in lukewarm water below 40°C (104°F). To get best results, wash with soapy water or a neutral cleaning agent.
3. Rinse the filter with clean water and dry thoroughly before re-installing.



## IMPORTANT

**DO NOT forget to install the air filter. If the air conditioner is left to operate without the air filter, dust is not removed from the room air and may result in machine failure. When the air inlet grill and cabinet are dirty, wipe with lukewarm water (below 40°C). Use of a mild detergent is recommended.**

## END OF SEASON CARE

1. Operate the fan alone for half a day to dry out the inside of the unit.
2. Turn off power and remove plug from wall socket.
3. Clean filter.
4. Store (covered) air conditioner in a dry location.



## CAUTION

**When installing and/or removing the air conditioner from the window, ensure that caution is taken to prevent it from falling backward. It is recommended that installation or removal of the air conditioner is done with assistance, to prevent injury to persons or damage to the unit or property.**

## DISPOSAL

Check for local regulatory compliance regarding the approved and safe disposal of this appliance.



# Troubleshooting

Occasionally a problem may arise that is minor in nature, and a service call may not be necessary. Use this troubleshooting guide for a possible solution. If the unit continues to operate improperly, call an authorized service depot or Danby's Toll Free Number **1-800-263-2629** for assistance.

PROBLEM	POSSIBLE CAUSE	SOLUTION
Air conditioner will not operate	<ul style="list-style-type: none"> <li>No power to the unit</li> </ul>	<ul style="list-style-type: none"> <li>Check connection of power cord to power source.</li> <li>Check fuse or circuit breaker.</li> <li>The power cord "RESET" button must always be pushed in (engaged) for correct operation.</li> </ul>
Inefficient or no cooling	<ul style="list-style-type: none"> <li>Dirty air filter</li> </ul>	<ul style="list-style-type: none"> <li>Clean/replace air filter</li> </ul>
	<ul style="list-style-type: none"> <li>Unit size inappropriate for application</li> </ul>	<ul style="list-style-type: none"> <li>Check with dealer to determine proper unit capacity for application</li> </ul>
	<ul style="list-style-type: none"> <li>Blocked air flow</li> </ul>	<ul style="list-style-type: none"> <li>Remove obstruction from grill or outdoor louvres</li> </ul>
	<ul style="list-style-type: none"> <li>Power interruption, settings changed too quickly, or compressor overload tripped</li> </ul>	<ul style="list-style-type: none"> <li>Turn the unit off and wait 5 minutes before attempting to restart</li> </ul>
Noisy unit	<ul style="list-style-type: none"> <li>Loose parts</li> </ul>	<ul style="list-style-type: none"> <li>Tighten loose parts</li> </ul>
	<ul style="list-style-type: none"> <li>Inadequate support</li> </ul>	<ul style="list-style-type: none"> <li>Provide additional support to unit</li> </ul>
Odors	<ul style="list-style-type: none"> <li>Formation of mold, mildew, or algae on wet surfaces</li> </ul>	<ul style="list-style-type: none"> <li>Clean unit thoroughly</li> <li>Place algaecide tablet in base pan</li> </ul>
Water dripping outside	<ul style="list-style-type: none"> <li>Hot and humid weather</li> </ul>	<ul style="list-style-type: none"> <li>Condensation run-off is normal under these conditions.</li> </ul>
Water dripping inside	<ul style="list-style-type: none"> <li>Unit is not properly angled to allow water to drain outside</li> </ul>	<ul style="list-style-type: none"> <li>Unit must be installed on an angle for proper condensation run-off. Check the unit and make any adjustments.</li> </ul>
	<ul style="list-style-type: none"> <li>It is an extremely humid day</li> </ul>	<ul style="list-style-type: none"> <li>On an extremely humid day, this effect is expected. No action required.</li> </ul>
Ice or frost build-up	<ul style="list-style-type: none"> <li>Low outside temperature</li> </ul>	<ul style="list-style-type: none"> <li>When outdoor temperature is approximately 18.3°C (65°F) or below, frost may form when unit is in cooling mode. Switch unit to FAN (only) operation until frost melts.</li> </ul>
	<ul style="list-style-type: none"> <li>Unit air filter is dirty</li> </ul>	<ul style="list-style-type: none"> <li>Remove and clean filter</li> </ul>

## NOTES:

- If circuit breaker is tripped repeatedly, or fuse is blown more than once, contact a qualified technician.
- When the unit is installed using proper installation steps, the unit is properly tipped toward the outdoors to allow for condensation run-off.

## LIMITED IN-HOME APPLIANCE WARRANTY

This quality product is warranted to be free from manufacturer's defects in material and workmanship, provided that the unit is used under the normal operating conditions intended by the manufacturer.

This warranty is available only to the person to whom the unit was originally sold by Danby Products Limited (Canada) or Danby Products Inc. (U.S.A.) (hereafter "Danby") or by an authorized distributor of Danby, and is non-transferable.

### TERMS OF WARRANTY

Plastic parts, are warranted for thirty (30) days only from purchase date, with no extensions provided.

*First Year* During the first twelve (12) months, any functional parts of this product found to be defective, will be repaired or replaced, at warrantor's option, at no charge to the ORIGINAL purchaser.

*To obtain service* Danby reserves the right to limit the boundaries of "In Home Service" to the proximity of an Authorized Service Depot. Any appliance requiring service outside the limited boundaries of "In Home Service", it will be the consumer's responsibility to transport the appliance (at their own expense) to the original retailer (point of purchase) or a service depot for repair. See "Boundaries of In Home Service" below. Contact your dealer from whom your unit was purchased, or contact your nearest authorized Danby service depot, where service must be performed by a qualified service technician. If service is performed on the units by anyone other than an authorized service depot, or the unit is used for commercial application, all obligations of Danby under this warranty shall be void.

*Boundaries of In Home Service* If the appliance is installed in a location that is 100 kilometers (62 miles) or more from the nearest service center your unit must be delivered to the nearest authorized Danby Service Depot, as service must only be performed by a technician qualified and certified for warranty service by Danby. Transportation charges to and from the service location are not protected by this warranty and are the responsibility of the purchaser.

Nothing within this warranty shall imply that Danby will be responsible or liable for any spoilage or damage to food or other contents of this appliance, whether due to any defect of the appliance, or its use, whether proper or improper.

### EXCLUSIONS

Save as herein provided, by Danby, there are no other warranties, conditions, representations or guarantees, express or implied made or intended by Danby or its authorized distributors and all other warranties, conditions, representations or guarantees, including any warranties, conditions, representations or guarantees under any Sale of Goods Act or like legislation or statute is hereby expressly excluded. Save as herein provided, Danby shall not be responsible for any damages to persons or property, including the unit itself, howsoever caused or any consequential damages arising from the malfunction of the unit and by the purchase of the unit, the purchaser does hereby agree to indemnify and hold harmless Danby from any claim for damages to persons or property caused by the unit.

### GENERAL PROVISIONS

No warranty or insurance herein contained or set out shall apply when damage or repair is caused by any of the following:

- 1) Power failure.
- 2) Damage in transit or when moving the appliance.
- 3) Improper power supply such as low voltage, defective house wiring or inadequate fuses.
- 4) Accident, alteration, abuse or misuse of the appliance such as inadequate air circulation in the room or abnormal operating conditions (extremely high or low room temperature).
- 5) Use for commercial or industrial purposes (ie. If the appliance is not installed in a domestic residence).
- 6) Fire, water damage, theft, war, riot, hostility, acts of God such as hurricanes, floods etc.
- 7) Service calls resulting in customer education.
- 8) Improper Installation (ie. Building-in of a free standing appliance or using an appliance outdoors that is not approved for outdoor application). Proof of purchase date will be required for warranty claims; so, please retain bills of sale. In the event warranty service is required, present this document to our AUTHORIZED SERVICE DEPOT.

**Warranty Service**  
In-home

Danby Products Limited  
PO Box 1778, Guelph, Ontario, Canada N1H 6Z9  
Telephone: (519) 837-0920 FAX: (519) 837-0449

**1-800-263-2629**  
07/13

Danby Products Inc.  
PO Box 669, Findlay, Ohio, U.S.A. 45840  
Telephone: (419) 425-8627 FAX: (419) 425-8629



## AIR CONDITIONER

All repair parts are available for purchase or special order when you visit your nearest service depot. To request service and/or the location of the service depot nearest you, call the TOLL FREE number.

When requesting service or ordering parts, always provide the following information:

- Product Type
- Model Number
- Part Number
- Part Description



**MODEL**  
**DAC080EB3GDB / DAC120EB3GDB**